



**GLOBAL ENVIRONMENT FACILITY (GEF) NGO
CONSULTATION**

**December 4, 2006
The World Bank, H Auditorium, 600 19th Street, N.W.
Washington,
DC**



1.0 Opening Remarks by Co-Chairs: GEF Secretariat and GEF NGO Network

Dorothy Manuel, Executive Director of ZERO Regional Environment Organization, Zimbabwe, and Central Focal Point for the GEF NGO Network and Alaa Sarhan, Senior Institutional Officer/NGO Coordinator, Corporate Affairs, representing the GEF Secretariat, chaired the GEF NGO Consultation. The session opened with a brief introduction of the agenda items and introductions from participants.

2.0 Evaluation Office Issues

Rob Van den Berg, Director of Evaluation, introduced the first item on the agenda. He gave an overview of the key progress milestones with regard to the Evaluation Office.

Rob's intervention touched on the impact of evaluation and the catalytic role of country portfolio evaluation on capacity building within the GEF. He reported that the Philippines and Samoa were part of the first country portfolio evaluations and the full criteria for these evaluations are available on the GEF website for future referral and reference. Rob informed the consultation that although Council approved one evaluation per year, the two country evaluations per year were possible through combining missions. Rob mentioned that the case of the Samoa was interesting as a SIDS with unique problems.

Rob informed the consultation that the **Small Grants Programme (SGP) evaluation** would be starting in the near future and will be ready for presentation to Council in 2007. This evaluation would be interested in three key questions:

- Extent of relevance to GEF mandate,
- Effectiveness (what is the contribution to global environmental benefits)
- Efficiency and cost effectiveness (how successful is the GEF in getting communities involved in these global issues).

Rob outlined the scope and methodology for these evaluations as, firstly, a full portfolio review, then ten country case studies and ten video conferencing evaluations to ensure as broad a range of experiences as possible. The evaluation recognizes the importance of seeing what is happening on the ground rather than just looking at documentation. A stakeholder survey and review of the facilities would also be encompassed. Looking at what SGP is doing with other partners would be part of the process. The approach paper will be posted on the website to invite comments for the team to consider.

Rob touched on the Evaluation Office proposal to Council that the Independent Evaluation Office conduct the evaluation of OPS4 rather than contracting to consultants, as was the case with OPS3. He explained that from the previous evaluation, they observed that hiring outside consultants removes the learning curve, which was steep for the consultants and there were difficulties in the field with the consultants having to learn the basics because



they did not know what was going on. Much of the funding therefore went to learning rather than the evaluation itself. He argued that his office could achieve better results and substantial saving by doing the evaluations, as his office was independent of GEF as the consultants. He suggested extensive stakeholder consultations through neutral mechanisms to get the perspectives of stakeholders into OPS4 and it would be beneficial to GEF to integrate the evaluation into a report that would go into a report to the Council and the Assembly.

Regarding **Evaluation of Incremental Cost Assessment**, Rob explained the necessity for this and whether there was need to evaluate this. Rob believed there was not enough transparency of the concept and its application. He underlined the process as reviewing literature on incremental costs, the compliance review, technical policy review, online survey reviews and the analysis of qualitative information. The review had been conducted for 79 Full Size Projects (FSPs) and 61 Medium Size Projects (MSPs). Having gone through this process, he outlined the findings as GEF being a minority funder only paying 20% of project costs. Although the principle of incremental funding is alive in the GEF, the incremental costs for the GEF are less than 40% although originally the GEF planned to fund full budgets to meet incremental costs. There is confusion within the concepts and procedures of incremental costs and the reporting does not add value. The analysis and assessment remains weak with much confusion about incremental cost concepts and procedures. It was clear that GEF is not paying for projects that do not produce global benefits. His conclusion was that the incremental cost assessment and incremental cost reporting be dropped, as this was not beneficial in terms of cost and time spent doing this.

In his next intervention, Rob looked at **the Evaluation of Experience with Executing Agencies**. He concluded that the involvement of Executing Agencies (EAs) in GEF 3 was lower than the council had expected with only 38 projects, 8% of portfolio. He observed that Executing Agency's perspectives were not fully taken into account when policies are developed and the playing fields were not level for project development and interaction with recipient countries. He suggested that GEF should rethink its partner strategy, structure and philosophy for the existing ten agencies and new agencies created in OPS4.

Rob then turned his attention to the issue of **Evaluation of GEF Project Cycle and Modalities**. He expressed the view that NGOs are aware of the subject, particularly as executing agencies for implementing agencies. Everyone knows of the elapsed time problem (reference to a paper presented two years ago) and the need for more analysis. He explained that eleven evaluations departments were involved in the evaluation of the GEF project cycle. The scope of evaluation looked at all Medium Size and Full Size Projects proposals and enabling activities, with the emphasis on approvals. The current total reflects 1,926 Full Size and Medium Size Projects. GEF 1 proposals are alive in GEF 3 and the percentage of proposals approved during the replenishment period in which they were developed is going down dramatically. It takes 66 months to go from idea to effective



implementation. Many projects take short cuts and drop elements of the cycle especially in the preparation phase, reducing the time to 44 months.

The conclusion drawn is that the GEF is increasingly funding the past as waiting times increases back-projects and elapsed times are not linked in a significant way. Good projects come out of this cycle because it has taken into account realities on the ground through consultations. However, there is no correlation between good projects and elapsed time. There is no value added. Funding the past means that you fund past modalities and have not moved into programmatic activities linked to country priorities. With this scenario there is no single emerging fault factor, so there is no quick fix, therefore there is need to go back to the drawing board. There is need to move from more paper evidence up front, to more results-based management. This problem is also be linked to the fact that donor countries did not give enough money, the GEF cash flow problems and micro management, the council sending back projects, the Chief Executive Officer of GEF's lack of oversight, the secretariat's lack of transparency and task forces failing to put up clear strategies. It is also due to the STAP giving bad advice. In addition, Implementing Agencies (IAs) and Executing Agencies (EAs) should have taken better care of the process with regard to slow recipient country endorsement and lengthy NGO consultations. Everyone is guilty and there is no single entity to blame. The activities must be re-established around developing a new activity cycle that emphasises tangible results rather than paper-based evidence. He identified the three essential elements for the new cycle as; Identification phase (establishing eligibility, availability of resources and concept endorsement by recipient countries) and the go-ahead signal; Work programme inclusion and CEO endorsement.

Plenary Discussion

Andras Krolopp, Group for the Enhancement of Biodiversity (CEEWEB), Hungary, asked if there are any ideas in OPS4 on to how stakeholder consultations can be carried out so that civil society and NGOs can be prepared. It is desirable that NGOs have a bigger role in the monitoring and evaluation processes. He said it was desirable for EAs to have a bigger role and thought that decisions were made upon the recommendation from conventions and council. He asked why this should be so.

Felipe Villagran MERO LEC, Mexico, indicated that he was happy to hear that SGP is achieving so many good things, with variations from country to country. However, there is need for a more homogeneous criterion in steering committees. Are the specific criteria, mandate, composition and duration of mandate and selection criteria the same for all steering committees? Are the internal policies consistent? He suggested that it would be good to have a rotation period to facilitate a regular change of membership. He noted that monitoring is more important than evaluation and can set project back on track. However, this implies that the IA will have the policies to facilitate this type of in-project adjustment.



He suggested that global benefits are forgotten as the only legally binding documents are those between the IA and the country. There should also be a binding document that says that as you are using GEF money the global impact should be included as one of the key objectives.

Lucy Mullenkei, Indigenous Information Network, Kenya, proposed that NGOs be involved in the evaluation and monitoring. She reminded her audience that it was important to look at the NGO Network and Indigenous Peoples as partners in both areas and to acknowledge them as important actors and contributors. She proposed that when the way forward is charted there is need to see how this sector can be involved. She submitted that SGP is very important to small communities.

German Rocha, Corporacion Pais Solidario (CPS), Colombia, congratulated the Evaluation Office for an excellent document but challenged that it looks for better ways to measure comparative advantages and avoid overlaps. He also highlighted the competition between IAs and international organizations.

Boni Biagini, Program Manager, Senior Climate Change Specialist, GEF Secretariat, addressing some of the questions raised, underscored the need to provide additional information with regard to the Executing Agency's role and their involvement in policy formulation within the GEF. Presently, EAs do have a role in the GEF, developing its policy in response to convention guidance as they have a regular presence in task forces that work thematically. EAs should play the same role as IAs. She mentioned that the African Development Bank has a first and second project under the LDC fund.

Yabanex Batista from the Nature Conservancy (US), going back to a point made regarding task forces and strategies, asked whether EAs were being included in the task forces for the strategies. He referred to the expertise existing among the NGO community that can be included in these task forces. He supported the points raised by Felipe with regard to the SGP.

Response by Rob van den Burg

- On the question of inclusion of NGOs in stakeholder consultation for OPS4, there were no specific plans. In the previous review, there was evidence of good stakeholder consultations and the approach was relatively professional. Rob stated that he hopes to improve on what was done in OPS3, organizing regional meetings where as many members as possible can attend. With regard to GEF policy and strategy, Rob submitted that yes the conventions give guidance, Council decides and there is interpretation in between. The council does not do anything without the recommendation from the Secretariat and when the Secretariat starts to implement they usually seek guidance from focal area task forces. IAs play an important role and also draw on the expertise of EAs.



- On the subject of comparative advantages, oversight and safeguards and internal polices the annual performance report (June 2007) will look for the first time at oversight mechanisms. Internal policies are part of the safeguard system.
- The point on legal agreement with countries and the issue of global benefits is an interesting point which can be included in country portfolio evaluations. However, it was not a problem in Costa Rica.
- About NGO involvement in M&E and Task Forces, the M&E office is open to the involvement of NGOs especially where there is clear benefit and value addition. The GEF follows the general trend of CSO involvement and looks at this actively. Evaluators at local levels will be involved in the evaluations e.g. his organisation looked for local NGOs through IUCN (so why not the NGO Network?). We have to use these networks as we cannot approach individual NGOs.
- The question of the task force is an interesting question for CEO. The Evaluation Office will propose that there is external expertise in strategy development. On the measurement of comparative advantage, the evaluation has not yet done this task. Usually an overview on what EAs do is conducted in relation to its compatibility to the GEF mandate. It is something that needs to be taken up in OPS4 but it is difficult as it requires close study of the mandate and operations of the EAS and this means substantive work if the results are to be meaningful.

Alaa thanked Rob for a very informative session and announced the next agenda item as Question and Answer session with the GEF CEO.

3.0 Question and Answer Session with GEF CEO

After a brief welcome, Dorothy Manuel invited Madame Monique Barbut, CEO & Chairperson GEF, to address the consultation.

Monique expressed delight at her coming to share a few words with NGOs. Monique started by saying that she did not intend to go into detail on all of the issues and strategies for GEF under her leadership. She submitted her commitment and dedication to the GEF reform initiated under her leadership and her intention to raise the bar. After the GEF's 15 years in existence, there is need to take stock of what has happened and see where we want to go with it. Without a doubt, she wanted GEF to become stronger, more efficient and performance based. We will seek to use the scarce GEF resources more effectively, with a particular emphasis on strengthening the impact on the ground. Country ownership and country-driven are not vague words. It is one of the most important objectives. Just as important is the more efficient GEF dissemination of funds, to protect the environment and to raise the conditions of the poor people of the world. A revised project cycle that takes no more than 22 months from identification to implementation on the ground is under consideration. GEF will fund top quality driven projects in line with national priorities within a two-year period. GEF has a strong record of accomplishment with NGO support



and will build on this strength as GEF continues to provide an important window for direct NGO involvement in the GEF. The Small Grants Programme (SGP) continues to provide an important window for enabling the participation of NGOs and communities. Since 1992, the GEF has provided US\$282 million in funding for the SGP. For GEF 4 an agreement has been reached on a core allocation of US\$110 million to SGP, US\$27.5 million per year, a substantive increase that will help strengthen the GEF civil society partnership.

She highlighted the impressive start to the GEF partnership with the World Bank Development Market Place launched in 2006, with 30 funded projects, ten projects currently being supported by GEF, six of these from Africa. There are major efforts underway to generate major co-financing for this programme.

RAF funds can be requested by countries for financing of SGP activities. It is unfair to expect a country belonging to a group to draw upon limited group resources to supplement co-financing. Demand for group resources for medium and full projects is important and expected to increase. SGP under this scenario will be expected to attract other sources of core financing to supplement the core funds allocated within the GEF Corporate Programme. Graduation policy for countries that have received a significant amount of core financing is under preparation to open up this facility to other countries that have not yet benefited.

A new GEF is in the making that is committed to helping member states to conserve the local environment for the benefit of all. This cannot be achieved overnight. There are many challenges in our joint effort to transform GEF into a vibrant and streamlined institution committed to helping member states conserve their local environmental benefits for all. Monique submitted that she had no doubt that NGO/GEF partnership will allow us to achieve faster results to enhance the global environment.

Plenary Discussion

Khadija Razai, CENESTA, Iran, asked when and where we can add as an equal right the community driven priority (as opposed to country-driven priority concept) to have balanced projects, good information and improved ownership.

Tim Geer, WWF, Switzerland, posed another question related to the future, referring to grassroots level participation and adding to this the participation of the GEF at United Nations level.

A question regarding the new leadership against replication of projects was raised.



Felipe Villagran, Mexico, stated that he wanted to repeat the fact that NGOs have been waiting for these types of changes noting that there will be some opposition but also that there will be support. He asked if the CEO would expand on her vision vis-à-vis the private sector.

Congratulations were extended to the CEO for her recommendation to include the private sector. A question was raised in terms of the inclusion of the academic sector specifically with reference to developing new methods for monitoring and evaluation highlighting that there is a lot to draw upon that has been produced and peer reviewed.

Leslie Walling, Caribbean Conservation Association (CCA), Caribbean, raised a question on adaptation. For NGO and Least Developed Countries (LDCs), adaptation is a significant reality to be addressed. How will GEF approach the issue of adaptation?

In response to Monique's speech, Leslie had this to say: "Following up on replication question and having listened to you this morning, there are a number of issues intimately related which seem quite complex. The recommendation that will be made from the Evaluation Office regarding funding past projects will be very important. In the Caribbean, we cannot deal with climate change on a project type basis, hence working with the Bank and the GEF has allowed a regional approach. In the monitoring and evaluation and project design process there will be a way to merge projects with national priorities".

Libasse Ba, ENDA, Senegal, thanked Monique for her clear, specific introduction which was in line with members' concerns. Coming from a Third World country and although he had not asked her predecessor some of the questions weighing on him, he had at last found some answers to questions regarding long delays, cycles, etc. According to Ba, it was a relief to know that the wish expressed in Nairobi to take adaptation out of the GEF activities and create a separate fund located outside the GEF had not been realised. If that had become a reality, it would have been a signal of failure of GEF policy.

It was in this context that he called on all present to support Monique's proposal for a change. "Until now it is true that all adaptation projects are GEF projects, so it does not make any sense to take adaptation out of GEF. I feel that everybody should support you when you talk about change," Ba said. He also applauded Monique for speaking in French during the Third GEF Assembly, Cape Town, South Africa. "Delegates whose main language is French receive documents in English and do not fully understand the subtleties. Every time you speak in French, you do a favour to the French speakers," said Ba.

Sahabi-Abed Salah offered his contribution in French like his colleague before him. He asked if the GEF had everything it needed to implement the strategy. He went on to say that it seemed that GEF wants to implement this radical change single-handedly. He questioned the role of the NGOs within this radical change under implementation which he



underlined was very important to reach the ambitious goals outlined so far. He offered to facilitate visits to various projects when Monique visits Algeria.

Response from Madame Monique Barbut, CEO & Chairperson GEF

On the question of ownership and to whom the project belongs, Monique explained that the GEF is an intergovernmental organization. Its shareholders are governments to whom GEF must deliver a certain number of things. The governments have to feel ownership first. Most governments do not even own their projects today. So at least in the government there are projects that they need.

Government is a general interest, but not the sum of interests. There are certain groups, which are excluded from the debate. The problem is not to bring every group in, but to make sure that the groups important to the GEF are incorporated.

Monique explained that her current strategy in terms of immediate GEF reform was to concentrate on the “kitchen” of the GEF and the IAs. Later she will eventually look at other “kitchens”. She was aware of other programmes, which GEF would study.

Monique explained that she has not taken to Council the NGO report, because firstly, her agenda had grown much bigger this time and every subject on the table needed to be discussed. Secondly, the document needs to reflect the new direction being discussed and take into consideration the interaction with the SGP, Focal Points (FPs), and National Dialogue Initiative (NDI). The relationship between the NGO Network and the GEF needs to be a two-way relationship. Monique emphasized value addition, stating that she will not give anything away if it is not clear what is being brought to the table. It is the only way to bring honest and responsible relationships. There will be no philanthropy from the GEF. Already two-thirds of the projects have been cut down, as the resources are insufficient to meet all these costs and there would be no new projects coming on stream before 2010. At present, she did not feel that she had an instrument with enough capacity to manage more funds, until it is streamlined. She stated that she would not compromise on major principles or the GEF will have no future. The day GEF can answer questions in a more transparent manner is the day GEF should be ten times bigger than it is today. The portfolio will be ten times bigger, but to attract other donors there must be trust.

Regarding replication of projects, Monique explained that GEF does not have enough money to be more than a seed money mechanism for the global environment. This could only become possible when GEF money increased 15 fold. While environmental problems are accelerating, the financing block of the GEF remained stable, thus it was not possible to finance the increasing issues on the scale required. So once GEF has seeded a project, it was time to get out of the GEF and seek funding from other sources.



Monique reaffirmed that she would be working hard on the private sector engagement and hoped that by June 2007, she would have a new strategy. What she intended to build was a GEF for the private sector, just as there is a GEF for governments of the world. New tools must be developed to attract companies to come and work with GEF. She took the opportunity to thank WWF who have given her a staff member for six months to develop a strategy for engagement with the private sector. In June she promised there would be a revolutionary approach in this regard. At this time, she challenged NGOs and the academic sector to come up with similar mechanisms.

Monique told participants that adaptation was a favourite subject dear to her heart and that she was disappointed to learn during the Climate Change COP12 in Nairobi, that the countries who contributed the least to the problem will pay the heaviest price. She submitted that she would like to concentrate on the issue of adaptation, which is also linked to GEF growing ten fold what it is today. “Adaptation is aligned to GEF, which is its natural home. We cannot cut the instrument and divide the tools, competing one against others but we must work in synergy. GEF is already working on adaptation with US\$200 million earmarked to this subject but adaptation projects must be linked to all the subjects in GEF as adaptation is a transectoral subject, not a focal area,” she said.

Monique responded to the last two questions saying that she comes with energy and an ideal, without this there would be no point in fighting. She pointed out that she could have a very easy life in the GEF but she is not a typical civil servant. Because of her commitment, she is challenged to implement not a mega project but a strategy. “For instance if you talk about desertification in Africa it will require all of these activities, all of these projects, but we do not need the Council to look at every project. The job of the Secretariat and Council is not to look in detail at every single project as we have agencies with far greater capacities to do this. What we need to bring to the table is a direction and a goal. There will be infrastructure projects, capacity building within an overarching strategy that says this is what I want to do. The NGOs have their place in this strategy. The SGP will have to position itself within this strategy. I have to start building GEF capacity today, not a little bit here and there, but holistically. Everyone should work in the same direction to achieve common goal,” she concluded.

Dorothy Manuel thanked Monique Barbut for an informative session in which she outlined very cogent plans for GEF reform. In summation, Dorothy scanned through the key issues outlined by Monique being open to new ideas and partnerships as she steers the re-engineering the GEF. Dorothy noted the immense energy, commitment and passion vibrantly visible as Monique shared her new vision for GEF. In conclusion, and speaking on behalf of the GEF NGO Network, she submitted that the network overall is encouraged that there will be a lot of positive reform for the betterment of the GEF. Dorothy highlighted that as the GEF undergoes reform, there are clearly new opportunities for the



re-launching of the GEF NGO Network, as the network begins to reposition itself and crystallizes its vision, goals and objectives.

4.0 Focal Area Strategies for GEF4 – Working Drafts and Proposed Process

Peter Bjornsen, Senior Policy Officer, Operations and Business Strategy, GEF Secretariat, presented an overview of focal strategies for GEF 4.

Peter advised the consultation that his team had requested to provide a background/operational approach rather complex structure that could be simplified that revised focal area strategies. He explained that there is a strategy paper for focal areas, which the CEO decided, would serve, as interim strategies for GEF 4 with the proviso that this document needs to be further developed to include the linkages between the four focal areas. The feeling was that the present papers were not focused enough on a specific set of issues but all-embracing in their nature. By simply looking at focal areas many issues were likely to be lost. Adaptation for example touches many focal areas. Forest management is another example of a cross-cutting issue, which need to be harmonized. The CEO decided that results-based management relies heavily on a specific framework instead of presenting a finalized RBM framework in December the plan is to hold off until the GEF had revised strategies which will also have an indicator framework.

Finally, also required is a synergetic look at approaches taken towards capacity development, knowledge management and the private sector. The focal area strategies need to be combined into an overarching strategy for the GEF.

Explaining the process, Peter pointed out that the first revisions were posted on the GEF website in October. Comments received from six council members were also posted on the website. Based on these comments and the discussion in Council during the consultation week, the revision and harmonization would take place over the next six months. A new set of strategies will be presented in June 2007, encompassing a simplified approach. This process will be opened up to experts to allow for a fresh look at the strategies. As part of this process material will be circulated to all interested parties.

Plenary Discussion

Djim Nanasta, ENDA, Senegal, mentioned that his main concern was how NGOs could become involved in the review of the Focal Area Strategies. He suggested that as the document was still in draft form NGOs could be invited to give comments and also be included in the process right to the end. He was however unsure how NGOs would be included in this process to enable them to give the maximum input.



Tim Geer, WWF, commented that the strategies GEF was looking at were a positive step forward. The biggest challenge will be linking these with operational strategies as keeping them separate meant GEF will never meet the challenges. He posted the following questions. What are the plans are for operationalizing these strategies. What are the roles of different actors and the value-added at different points and how can we identify where we should be participating, not only on supply side but demand side.

Response by Peter Bjornsen

Peter underlined two aspects to this question. The first was how the NGOs can get more involved in the development of the strategies and the second the idea of having more focus. Peter underscored the cross-cutting nature of most NGO's work and the linkage between the environment and sustainable development. This aspect needs to be reflected in the strategies. On the subject of NGO involvement, he encouraged NGOs to comment on interim strategies. Secondly, in a process that the CEO will propose to Council drafts will be circulated. This will be another opportunity for NGOs to make an input.

5.0 Strategy for Financing Biosafety

Pat Belinti, GEF Secretariat, presented the Strategy for Financing Biosafety, to be discussed as agenda 15 in Council. The document contains a proposed strategy which should help build capacity of countries to meet the Cartagena Protocol.

This was followed by an intervention from NGOs by Khadija Razavi, CENESTA, Iran. She highlighted the importance of the participation by all stakeholders at all levels given that there was a lack of civil society participation in general. She reiterated her request that GEF funding documents make it clear that civil society must participate to comply with policies. She suggested that the NGO Network be included and consulted further suggesting the idea of a steering committee with at least one member of the NGO Network. She welcomed the recommendation with regard to public participation and expected that this would be clearly spelt out in the GEF funding document.

Although protocol was very clear on participation the problem lay with enforcement. She underscored the need to share information and encouraged UNEP to involve the NGO Network, particularly with regard to training and capacity building. She also believed there was need to regularly update the Network with regard to capacity building activities. There is need to be focused on country coordination and stakeholder participation on questions/answers to issue such as the impact of Green Revolution on poverty and hunger. She also spoke about the need to ascertain responsibility for mistakes caused by the Green Revolution, particularly with regard to Genetically Modified Organisms (GMOs), which threaten the existence of traditional crops/foods. There is an obvious contradiction she noted, on the one hand trying to safeguard biodiversity through the CBD while propping



up GMOs through biosafety on the other. There was no question about what will happen to small farmers as seeds are at the core of life. In her opinion, diversification had been the most successful strategy of innovation. This was because it increases the options favourable to farmers' chances of adapting to changing environment. But despite this, there was need to be conscious of the freedom of farmers to save seeds, against biopiracy, to trade seeds openly and freely. "We have to be conscious that seeds are a gift of nature not a private commodity. Our human duty is to preserve Mother Nature, so the biodiversity of seeds should be rooted with those who conserve/use them," she said. She added that strategies and technology for further development of seeds should be based on wealth and ingenuity of farmers and seed communities (See Annex 2 for full presentation).

Plenary Discussion

A participant made reference to the presentation by Khadija in which she underlined the need for the full participation by all stakeholders at all levels (including monitoring and evaluation.) He lamented the lack of stakeholder involvement citing the absence of clear guidelines on what countries must do to receive funds. He believed strongly that the network should be involved and consulted through the Steering Committee. This was necessary to help the network members distribute the information among their partners. The plenary discussion revealed that there were serious concerns with GMOs. The general consensus was that Cartagena is a good idea but the world risked "irreversible" damage if NGOs waited for governments to agree.

Response by Pat Belinti

Pat agreed with the first part of the intervention by the NGOs on the importance of public consultations and conceded that a strategy needs to be developed on this. Pat mentioned that discussions had begun with UNEP who have developed a transparent policy and have a wealth of information on their website.

Referring to the second part of the NGO statement, Pat advised that this was a firm mandate from COP to build capacity of countries to enable them to make their own decisions.

A UNEP representative reiterated what Pat said concerning making all information available on biosafety projects on their website. UNEP advised that a virtual library had been started through the Capacity Building Information Centre (on the BCH) and this should be available by the end of the year.

6.0 Implications of amending the Instrument to reflect the designation of the GEF as financial Mechanism of the UNCCD



Andrea Kutter, Program Manager, Natural Resources Specialist, GEF Secretariat, presented GEF as a financial mechanism of the UNCCD. He explained that the paper originated from the Council meeting in Cape Town where the initial request was made. The paper has three main chapters, each focusing on the legal, operational and financial aspects. In developing the legal, the authors sifted through Conference of Parties (COP) decisions. The paper, in many ways, is responsive to COP requests.

Plenary Discussion

Khadija Razavi, CENESTA, Iran, pointed out the insufficient funding for this focal area which is still bothering people on the ground. She regretted that the decision in Cape Town was made in inequitable manner. Projects regarding sustainable land management as currently defined need to reflect a participatory approach involving local governments, communities, women, civil society, etc. at each and every step. The NGO community underlines the importance of this towards achieving the Millennium Development Goals (MDGs) which also contribute to climate change. We should be investing as much as others and more at times on issues related to poverty, drought, climate change, etc. and tackle these in a holistic manner. Good governance and involvement of all is the foundation for good projects. She noted even countries that boasted land use management plan, access to land, community land tenure etc. are still had problems. It was important to allow people to own these processes. While she welcomed the amendment to the GEF instrument, she hoped it would generate more resources.

The GEF paper supported jointly by UNCCD and GEF is important as we have reached joint conclusion on how to amend instrument.

7.0 Progress Report on Implementation of the RAF

Kiran Pandey, Senior Environmental Economist, Operations & Business Strategy, GEF Secretariat, briefed the meeting on the RAF emphasizing the following points: (i) GEF was still getting ready to implement the RAF and (ii) 8 regional workshops had been conducted with invited focal points and NGOs involving 139 countries, and 300 participants, 62 of these being NGOs. Workshops were well received but there were concerns that there was not enough consultation about the RAF prior to its adoption. Countries have expressed satisfaction with those country consultations and GEF was encouraged by this consultation and representation. However, some problems highlighted included adequacy of the consultations, the implication of RAF on specific types of projects and programs, among which was the impact on NGOs and SGP. There was also the burning question of modalities for changes to the RAF, ideas in terms of how RAF would be evaluated, the transition to the RAF and how this would occur in terms of status of projects and the transition between GEF3 and 4. Finally, there was the question of the needs of focal points under the RAF.



It was brought to the attention of the consultation that initial allocations were publicly disclosed and countries shall send prioritised lists by 15th September to see national priorities for the next replenishment period. The allocations are available on the website for all to see. He reemphasized that the 4th replenishment was not yet effective.

He reported that 75 countries had sent in letters indicating priorities for GEF 4. However, there was concern that the focus of the letter was not projects and that there was a mismatch between projects and the strategic priorities of the GEF. The GEF's priorities were evolving and that constituted part of the problem and since some countries were applying for the first time, the projects were out of sync.

The agencies that countries were proposing to work with in numerous instances did not have the comparative advantage in that area. The CEO wrote back to all focal points suggesting GEF would begin a dialogue with all countries focusing on what the country priority areas were and how these might be split across different priority areas. The dialogue had already begun and in general countries had responded positively. However, this interaction would continue to assist countries vis-à-vis their priorities and the best use of funds available to benefit the global environment and their priorities.

Kiran went on to talk about evaluation of the RAF which would take place after a period of two years.

Plenary Discussion

Commenting on the issues, Felipe Villagran observed that focal points never stayed long enough in their job to fully understand the GEF processes. The GEF Secretariat cannot expect too much in this regard.

Andras Krolopp expressed his appreciation for the eight consultations conducted so far. He was, however, concerned that quite a number of recommendations from the consultations had not yet been incorporated into the document. He asked if GEF was happy with only 75 countries responding. He reminded participations about a GEF Assembly at which venue NGOs requested the deadline for submission be extended to allow national dialogue on priorities. The fact that only 75 out of 170 countries responded seemed to confirm that time was indeed short. He wanted to know if there was any way to link the consultations started from GEF Secretariat side to the country dialogue initiative or whether it was completely beside the point. He concluded by asking the GEF Secretariat to give some indication of pipeline management and how it will prioritize. How can the NGO Network work with the GEF on this?



The GEF NGO Network asked for more time to prepare national priorities to ensure consultations to inform the process. The question on nearly everybody's lips viz: What will happen now with national priorities?

Response from Kiran Pandey

Kiran shared the concerns raised by Felipe on the rapid turnover of focal points, but this was not peculiar to focal points alone. "We will always have new focal points and Council members and we also have a new framework which is new for everyone in the system so we are learning as well. But we really need to work together to make it happen. The RAF is new to the whole system (even to the GEF). So everyone has to work together," he told the meeting.

In response to Andras, Kiran said the GEF have come up with a 20-point plan to deal with workshop recommendations. The first step was to post the minutes from all consultations on the website so that everyone can view and comment on them. Kiran explained that GEF was also integrating recommendations before the new system is implemented. Some of them, i.e., in relation to indicators used in RAF, are more long term issues which will be dealt with during the midterm review. Others will be incorporated right away. The dialogues will be ongoing. Countries will consult on a strategic level, especially on what they want.

Funke Oyewole, Team Leader, Corporate Affairs, GEF Secretariat explained clarified there are two kinds of dialogues: the country dialogue and country dialogue initiative (broad approach). These, she said, were entirely different animals: country dialogue are ongoing in-country when they discuss their strategic priorities while country dialogue initiative is a broader initiative when IAs and the GEF Secretariat meet with country stakeholders to discuss a broad number of issues and not just programming. These are provided to countries at their request.

Kiran explained that there are changes on RAF and project cycle, rules and procedures which are all interlinked. He recommended that the (political) points be shelved until the next session with Ramesh Ramankutty.

8.0 Rules, Procedures and Objective Criteria for Project Selection, Pipeline Management and Cancellation Policy

Ramesh Ramankutty, Head, Operations & Business Strategy, GEF Secretariat, presented the next session saying that RAF was a new game for everyone and was hopeful that all stakeholders were going to work together. He told participants that Monique Barbut would be coming up with a new project cycle which will be ready for June 2005.



It would take a maximum of 22 months for a project to be approved within the new cycle. This would be a vast improvement in terms of the time frame. The aim is to develop clear milestones which could be monitored closely and any milestones not meeting those checkpoints would lead to cancellation of projects, he said.

Said Ramesh: “For 15 years we got use to a certain way of doing business, RAF changes this in a fundamental manner. There will be starting problems but hopefully we can work together to iron these out. Regarding the specific paper for Council which alludes to a major change that we want to do in conducting business concerning the GEF project cycle, a cycle we love to hate. For years we have heard about how long it takes to get a GEF project approved and may have heard that there is always a backlog of projects. The process puts on the higher end 66 months from concept implementation to start up, three and a half to five years is the record. The time has come to rethink the way we do business. There are few benefits if any to be obtained with tinkering with project cycle at margin. You may have seen one streamlining proposal after another proposing tinkering at the margin, some have lengthened their cycle. It is in this context that the CEO accepted proposal to change this once and for all. There is a plan to work in close collaboration over the next six months to have a new project cycle to ensure that it will not take more than 22 months from idea to start up,” said Ramesh.

He continued: “The paper being presented to council has to be seen in that context. The paper proposes things we want to do as we set the stage for a major overhaul of the project cycle. We will apprise Council of the need to have pipeline management strategy in place so projects do not take more than 22 months. When this is agreed, we need to stick to that. There will be variations but the problem with current system is that there is no focus or attention on how concepts are moving through pipeline. GEF intends to develop clear milestones and elapsed times during implementation and monitoring. It will give the CEO the discretionary power to cancel or terminate projects not meeting the set standards. The new system will start focusing on activities not performance according to the calendar. We do hope there will be fixed time lines to deal with situations that emerge on the ground.”

Ramesh also talked about partnership programs in land degradation, etc. including all activities in which GEF engages with countries over a long period of 5-10 years. All of these projects were sub-projects, he said, adding: “Past approval procedure has been in the context of each participant proposal. Council said at the last meeting that the GEF Secretariat needs to come up with a standardized way of approaching this i.e. if at a certain level it goes to Council, under that level it can be approved by the CEO. The third level delegates responsibility to IAs. We think such an approach will increase transparency as Council is fully aware of the types of sub-projects being approved.”

Regarding cancellations/suspensions, Ramesh said the paper provided statistics with data on concepts which are in the pipeline and project proposals approved by Council but not



by the CEO. He noted that a large number of these projects had been there for more than 3- years. “In the past this data has been generated and although we have weeded out some of the non-moving proposals, there has never been a clean-up of the pipeline. The CEO is asking for approval to clean up the pipeline and there are some suggestions as to how this should be done. The CEO would like to reserve the right to cancel things out of pipeline. Once the project is approved by the approving authority, they are the final decision maker. These are the three items which may look disconnected but in the context of how we want to change the way we do business there is some coherence,” he said in conclusion.

Plenary Discussion

On behalf of the network, Felipe Villagran responded that the network was quite happy with the paper which contained “many positive things.” The network was pleased to learn that sub-project approval, especially for those of less than US\$500,000 would now be done by IAs/EAs. The network’s view was that it would be a good idea to divide subprojects into categories and thresholds. He wondered however, if the new proposal was not a case of new wine in an old bottle. In the good old days you first suspended a project and then terminated it. Is this different? The network was also concerned about the selection criteria. Public participation was described as “loose” and often conspicuous by its absence at the beginning. NGOs were often called in for intervention in the middle of project cycle. Another bone of contention was that there are no safeguards, though, there is the need for them.

“We see no safeguard on the part of GEF in the form of any kind of consultation and participation with communities; these are loose although there is need for them. They get to the pipeline, get approved, start and then we have to jump to safeguard by consulting. This type of process does not make sense. We always look like a pain in the neck but unless you let us start in the beginning with participation and consultation, it will not work nor will it be inclusive,” said Felipe.

Andras Krolopp raised a couple of comments. He saw some good in the introduction of the US\$500,000 threshold, but wanted to know what would happen if countries decided to flood the pipeline with such projects. “We are talking about clearing the pipeline and we are just wondering if a study has been done to analyze why there are projects in pipeline for years? Is it lack of capacity? Can we have figures regarding the cancellation of projects as quite a few projects have already been endorsed? Will these lose the money? Lastly, on one hand we have a serious re-pipelining issue, on other hand GEF is encouraging governments to resubmit in a positive manner. How is this going to work?” he asked.

Andras expressed shock at the prospect that one third of the projects could be terminated. According to him the several countries working on priorities would wake up one day to be



told that these do not fit with the GEF priorities and have certain projects cancelled. This was demoralising, he noted.

Andras raised the issue of the billion and a half dollars in the pipeline, concepts which have not been approved by Council. He wanted to know if this was the number that the CEO wanted to reduce to US\$700 million. This reduction translates to approximately US\$30 million in PDFs. The question is how you cancel them legally. If the project is not going through, should these PDFs not be terminated? Andras reminded the meeting that one in every third project would be terminated. Projects in the pipeline are not yet approved. “Are we talking about cancelling project preparation activities, not project cancellation?” he wondered.

Response by Ramesh Ramankutty

Ramesh explained that the threshold of US\$500,000 does not mean that all projects up to this limit be approved by IAs. For example, say Council approved an umbrella project on climate change with 120 countries and there are 120 subprojects, each may be US\$350-400,000. The document agrees that one by one project will not go back to the secretariat/council but that they will be approved by UNEP. We are proposing this so that in future when we have an umbrella project this will kick in so there will be no negotiating on a project by project basis. Also with the investment funds many in international waters many have subprojects; these too are projects under an umbrella project. Concerning safeguards, the principle on which GEF operates is to function under the policies and procedures of agencies. The issue arises when an IA does not have a safeguard policy, but if they do, it kicks in. If there is a concern that an IA does not meet international standards then this can be raised that with Council. Regarding criteria, this is of great concern to the CEO and as we stream line this will be revisited. We note that it is well overdue.

Reference to cleaning the pipeline, the tables on page 1 and 2 of the paper reflect US\$1.3 billion. This is a significant share for more than two years. The decisions of cancellation are a process we are going through now. If you have a pipeline of a billion and a half as we enter GEF 4 it means that half of the replenishment is already mortgaged. The concern was that we are making claims on GEF 4 without knowing policy environment and this leads to the decision to clean the pipeline to one that does not exceed US\$700 million. This is the process we are going through. We have to make some difficult decisions on things languishing in the pipeline, looking closely at concepts that do not reflect priorities in GEF 4. Some of items reflect conversations that we are having on a daily basis. The list may not be perfect but it sends a clear signal that the pipeline will be US\$700 million. There is no point in proceeding with a PDF when the project will not be funded. In terms of cleaning up the pipeline, regarding the PDF A and B, there is no need to insist on the PDFs if some projects will not be approved by Council. However, he added that the deadlines should remain in place for the purposes of flexibility.



He acknowledged these were “difficult” issues but emphasized the Council should find a way out. Ramesh also took time to explain that the difference between suspension and termination, which he said were loosely used. “Termination is when the Council arrives at the conclusion that it is not working; this is immediate. Suspension is when you have a suspicion that it is not working. There are conversations with countries to try to get a sense of where we can identify priorities for countries aligned with GEF’s priorities for GEF 4. We are reworking our focal area strategies which Council members feel is not sharp enough. We all agree that after 15 years there is need to re-focus. We will see sharpening in focal areas by June 2007 and we will have to work with countries to ensure alignment happens for the future. This is why there is no deadline for this so we can work flexibly,” he said.

The next agenda item was the presentation of three case studies as follows:

- **Practicalities of Monitoring Sustainability and the Progress of the Conventions: Three Examples Using Remote Sensing - Benjamin White, Science Policy Officer, University of Maryland Global Land Cover Facility Institute for Advanced Computing Studies**

Ben White is a Science Policy Officer from the University of Maryland’s Global Land Cover Facility. His educational background is in geography, philosophy of science and logic. His professional background is on earth observing systems and the development of earth observing knowledge networks.

- **The Five Year Programme on Adaptation - MD. Golam Rabbani, Senior Research Officer, Bangladesh Centre for Advanced Studies (BCAS)**

Golam Rabbani is a senior research officer with Bangladesh Centre for Advanced Studies. He has worked on environment and climate change issues in Bangladesh for the last few years and currently holds the responsibility for the Climate Change and Health Impacts project under implementation in Bangladesh. He was a key person in “The Baseline Study on Disaster Risk Management and Climate Change Impacts, Knowledge and Understanding among Community People”.

- **Assessment of Marine Biodiversity Indicators for the Global Environment Facility Resource Allocation Framework (GEF RAF) in the South Pacific - Bevis Fedder, Researcher FSPI**

Bevis Fedder is a German M.Sc student studying at the University of Bremen. He is currently attached to South Pacific Foundation of the Peoples of the South Pacific (FSPI), Fiji, and engaged in collecting data in the South Pacific for his



thesis “Assessment of Marine Biodiversity Indicators for the GEF RAF in the South Pacific”.

Full presentations are contained in Annex 4 -6

9.0 Closing Remarks

Dorothy thanked all participants for their interest and active participation. She noted that the consultation was indeed a full day packed with interesting discussions and case studies. Said Dorothy in her closing remarks, “We have heard more about the GEF reform being undertaken under the leadership of Monique Barbut, CEO & Chairperson of the GEF. We have heard about the various partnership opportunities to be defined within the GEF Reform with the private sector, with the academia and most importantly for the NGOs.”

“The process on adaptation has been underlined. The formula used by the GEF to calculate Marine Biodiversity Indicators has been challenged. We have been given excellent examples of the use of remote sensing as a tool for monitoring sustainability and the progress of Conventions.”

“It is now time to process all this information and move forward with the re-definition of the GEF support structure, in our case the GEF NGO Network. Space has been created and this is a beginning of a fresh start to strengthen what works.”



ANNEX 1

GEF-NGO NETWORK CONSULTATION	
Monday, 4 December, 2006, 9.00am- 18.00pm The World Bank, H Auditorium, 600 19 th Street, N.W. Washington, DC	
09h00 – 09h30	Registration and election of co-chair (NGO) Opening Remarks by Co-Chairs: GEF Secretariat and GEF NGO Network
09h30 – 10h30	Evaluation Office Issues <ul style="list-style-type: none"> ▪ Evaluation Office Progress Report ▪ Evaluation of Incremental Cost Assessment ▪ Evaluation of Experience with Executing Agencies ▪ Evaluation of GEF Project Cycle and Modalities
10h30 - 11h30	Question and Answer Session with GEF Secretariat
11h30 – 12h30	Focal Area Strategies for GEF4 – Working Drafts and Proposed Process
12h30 – 13h00	Strategy for Financing Biosafety
13h00 -14h00	LUNCH
14h00 – 14h30	Implications of amending the Instrument to reflect the designation of the GEF as financial Mechanism of the UNCCD
14h30 – 15h00	Progress Report on Implementation of the RAF
15h00 – 15h30	Rules, Procedures and Objective Criteria for Project Selection, Pipeline Management and Cancellation Policy



15h30 – 16h00	<p>Practicalities of Monitoring Sustainability and the Progress of the Conventions: Three Examples Using Remote Sensing</p> <p>Benjamin White, Science Policy Officer, University of Maryland Global Land Cover Facility Institute for Advanced Computing Studies (confirmed)</p>
16h30 – 16h30	<p>The Five Year Programme on Adaptation</p> <p>MD. Golam Rabbani, Senior Research Officer, Bangladesh Centre for Advanced Studies (BCAS) (to be confirmed, tentative yes)</p>
16h30 – 17h00	<p>Assessment of Marine Biodiversity Indicators for the Global Environment Facility Resource Allocation Framework (GEF RAF) in the South Pacific.</p> <p>Bevis Fedder, Researcher FSPI</p>
17h00 – 19h00	<p>Open Discussion, Wrap up and Closing Remarks</p>



ANNEX 2

STRATEGY FOR FINANCING BIOSAFETY (DOC/C.30/8 NOV06)

The present document builds on Doc GEF/C.27/12 of October 2005 and the document “Elements for a Bio-safety Strategy” presented during the June meeting.

During our comments at the June meeting we strongly highlighted the importance of the full participation of all stake-holders particularly civil society groups at all level. We based our comments on the report of the Evaluation Office which rightly noted the lack of proper consultation with Civil Society in most cases.

We therefore welcome the contents of Para 20 at Page 4 “Focus on in country coordination and stake-holder involvement”. We again request that the GEF funding documents make clear recommendation about this issue and make it conditional for countries benefiting the funds to comply fully.

“The strategic focus” at Section III Page 2 Para 6 sub-sections C and E make mention of in country coordination and involvement of stake-holders in the enhancement of awareness raising and public participation.

Stocktaking Assessment (Page 3 Para 8)

The network would wish to be clear on the modalities of this assessment as regards who, which organization will be responsible. The network would wish to be consulted and involved in this process.

Involvement of a broad range of Implementing and Executing Agencies (Page 4 Para 22 & 23)

The network would wish to be represented on the proposed Steering Committee by at least one member.

We welcome the recommendations as regards public participation under item “Awareness Raising, Public Participation and Information Sharing” at Para 25 Page 5. We expect that these are clearly reflected in the GEF project documents.

Sustainability (Page 5 Para 27)

The network proposes that countries involved in the “Development of National Bio-safety Strategy”, the National Bio-safety Capacity Building Strategy and the National Coordination Mechanism mentioned at sub-section a,b, include Civil Society



representatives in the true spirit of participation and involvement outlined in the protocol. The protocol is very clear on this issue.

We reiterate our previous requests (Ref June meeting intervention) to be fully involved in all “monitoring/evaluation activities” (Ref Page 6 Para 29).

Conclusion

We request UNEP to share its accumulated wealth of knowledge on this issue to the network. We need to share such information to our broader network.

That UNEP involve the network through the country, regional, sub-regional activities in the future, particularly as regards training and capacity building.

We request the GEF capacity building unit to regularly update the network as regards its various capacity building activities – as the network is interested to be a party to all such capacity building activities.

We thank you Mr Chair, Ladies and Gentlemen for your kind attention.

This paper has been prepared jointly by:

Rajen Awotar (Regional NGO Focal Point for East Africa) and Khadija Razavi (Regional NGO Focal Point for West Asia)



ANNEX 3

NGO comments on GEF paper “Legal, Operational, and Financial Implications of an Amendment of the GEF Instrument to Reflect the Designation of the GEF as a Financial Mechanism of the UNCCD”(GEF/C.30/7Nov.2006)

First of all we wish to point out the inadequacies of funds as regards this focal area. Everybody is aware that this convention is the “Parent Pauvre” of all the GEF funded conventions.

Projects regarding “Sustainable Land Management”, if correctly designed and taking in account the community driven priorities at the same level as country driven priorities with a participatory approach involving local government, local communities, women, youth, small farmers, pastoralists, civil society etc in the process of decision making, implementation and M&E are bound to make a difference. Poverty alleviation, sustainable livelihood, enhancement of the ecosystems, income generation, sand dune fixation, combating desertification, land degradation, drought and realization of Millennium Goals will be tackled in a holistic manner.

Good governance and the involvement of all stakeholders in the process of sustainable development is a good opportunity to have high-quality project implementation of the Convention.

It would be good to know the countries where land use planning and community driven development have been undertaken as these could be good examples to be replicated in other regions having similar problems.

We thank you Chair, Ladies & Gentlemen for your kind attention!

This paper has been prepared jointly by:

Rajen Awotar (Regional NGO Focal Point for East Africa) and Khadija Razavi (Regional NGO Focal Point for West Asia)



ANNEX 4

PRESENTATION

THE FIVE YEAR PROGRAMME ON ADAPTATION

*presented by MD. Golam Rabbani, Senior Research Officer,
Bangladesh Centre for Advanced Studies (BCAS)*

Slide 1: FIVE YEAR PROGRAMME OF WORK ON IMPACTS, ADAPTATION AND VULNERABILITY TO CLIMATE CHANGE OF THE SUBSIDIARY BODY FOR SCIENTIFIC AND TECHNOLOGICAL ADVICE (SBSTA)

NGO Consultation
4 December 2006

MD. Golam Rabbani
Bangladesh Centre for Advanced Studies (BCAS)

Slide 2: CONTENTS OF THE PRESENTATION

- History of five year programme
 - Objectives of the programme
 - Scope of work
 - Key Elements
 - Deliverables and time frame
 - Expected outcome
 - Major Challenges
-

Slide 3: HISTORY OF FIVE-YEAR PROGRAMME OF WORK OF SBSTA

- Background discussion in different events
 - √ Decisions 1/CoP8, II/CoP9, I/Cop10 and 2/Cop 11
 - Formal Development Process
 - √ Adaptation In-session workshop (21 May 2005)
 - 17 parties took part in the discussion to identify possible elements of the programme of work
 - √ Informal workshop (17-19 October 2005)
 - 51 parties took part in the workshop
 - Specific activities were identified under a number of sub-themes of three major thematic areas
-



Slide 4: HISTORY OF FIVE-YEAR PROGRAMME OF WORK OF SBSTA**√ CoP 11**

- Adopts the five-year programme of work of the SBSTA on impacts, vulnerability and adaptation to climate change.
- All parties were requested to participate in the implementation of the programme of work.

√ CoP 12

- SBSTA agreed to further implement the five-year work programme.
- Identified specific focus areas, actions and deliverables from 2007 to 2009 to reach the objectives of the programme of work.

Slide 5: OBJECTIVE OF THE FIVE-YEAR PROGRAMME OF WORK

- To assist all parties especially developing countries including the least developed countries and small island developing states to improve understanding and assessment of impacts, vulnerability and adaptation.
- To make informed decisions on practical adaptation actions and measures to respond to climate change on a sound, scientific, technical and socioeconomic basis, taking into account current and future climate change and variability.

Slide 6: SCOPE OF WORK

The programme of work consists of three following thematic areas:

- Impacts and vulnerability
 - Adaptation, planning, measures and actions
 - Integration (cross cutting issue)
-

Slide 7: KEY ELEMENTS/FOCUS AREA

Five-year programme of work includes following elements or focus area.

1. Methods and Tools

- √ Activities will be undertaken to advance the following sub themes
 - promoting development and dissemination of methodologies and tools for impacts assessments, such as rapid assessments and bottom up approaches, including as they apply to sustainable development.
 - promoting the development and dissemination of methods and tools for assessment and improvement of adaptation planning, measures and actions, and integration with sustainable development.

2. Data and Observations

- √ Activities will be undertaken to advance the following sub-theme.
 - improving collection, management, exchange, access to and use of observational data and other relevant information on current and historical climate and its impact, and promoting improvement of observations, including the monitoring of climate variability.

Slide 8: KEY ELEMENTS/FOCUS AREA

3. Climate modelling, scenarios and downscaling

- √ Activities will be undertaken to advance the following sub-theme.
 - promoting the development of, access to, and use of information and data on projected climate change

4. Climate related risks and extreme events

- √ Activities will be undertaken to advance the following sub-theme.
 - promoting understanding of impacts and vulnerability to climate change, current and future climate variability and extreme events, and the implications for sustainable development.
-

Slide 9: KEY ELEMENTS/FOCUS AREA

5. Socioeconomic information

- √ Activities will be undertaken to advance the following sub-theme.
 - promoting the availability of information on socioeconomic aspects of climate change and improving the integration of socioeconomic information into impact and vulnerability assessments.

6. Adaptation planning and practices

- √ Activities will be undertaken to advance the following sub-theme.
 - collecting, analyzing and disseminating information on past and current practical adaptation actions and measures, including adaptation projects, short and long-term adaptation strategies, and local and indigenous knowledge.
 - facilitating communication and cooperation among and between parties and relevant organizations, business, civil society and decision makers and other stakeholders.
-

Slide 10: KEY ELEMENTS/FOCUS AREA

7. Research

- √ Activities will be undertaken to advance the following sub-theme.
 - promoting research on adaptation options and practices for adaptation, particularly addressing identified adaptation priorities and building on lessons learned from current adaptation projects and strategies.

8. Technologies for adaptation

- √ Activities will be undertaken to advance the following sub-theme.
 - promoting research on adaptation options and practices for adaptation, particularly addressing identified adaptation priorities and building on lessons learned from current adaptation projects and strategies.
-

Slide 11: KEY ELEMENTS/FOCUS AREA

9. Economic diversification

- √ Activities will be undertaken to advance the following sub-theme.
 - promoting understanding and the development and dissemination of measures, methodologies and tools for increasing economic resilience and reducing reliance on vulnerable economic sectors, especially for relevant categories of countries listed in Article 4, paragraph 9, of the convention.
-



Slide 12: OVERVIEW OF FINAL DELIVERABLES AND ACTIONS UNDERS THE FIVE YEAR PROGRAMME

Year	2007				2008		2009	
Session	Before/by SBSTA 26		Before/by SBSTA 27		Before/by SBSTA 28		Before/by SBSTA 29	
Focus area	Actions	Deliverables	Actions	Deliverables	Actions	Deliverables	Actions	Deliverables
1. Methods and tools	Submission by 15 May 2007 (parties) -Information on existing and emerging assessment methodologies and tools -views on lessons learned from their applications -gaps, constraints, opportunities		Miscellaneous Document (Secretariat) -compilation of the submissions	Synthesis Report- (Secretariat) -information and views contained in the relevant outputs from LEG (Least Developed Countries Experts Group), EGTT (Expert Group on Technology Transfer	Expert meeting at secretariat (parties+ developers and users of methods and tools+ ROs etc)	Report and other Output from the experts meeting (secretariat)		



Slide 13: OVERVIEW OF FINAL DELIVERABLES AND ACTIONS UNDERS THE FIVE YEAR PROGRAMME

Year	2007				2008		2009	
Session	Before/by SBSTA 26		Before/by SBSTA 27		Before/by SBSTA 28		Before/by SBSTA 29	
Focus area	Actions	Deliverables	Actions	Deliverables	Actions	Deliverables	Actions	
2. Data & observations			Submission by 21 Sept'07 (WMO and its member States, secretariat of GCOS (Global Climate observing System and ROs) -Information and views on how their work could contribute to improved understanding of climates, impacts, problems, deficiencies in data and observations at national and regional level. Also how to improve technical structure -Miscellaneous document (compilation of submissions by secretariat			Relevant parts of the report from the expert meeting		



Slide 14: OVERVIEW OF FINAL DELIVERABLES AND ACTIONS UNDERS THE FIVE YEAR PROGRAMME

Year	2007				2008		2009	
Session	Before/by SBSTA 26		Before/by SBSTA 27		Before/by SBSTA 28		Before/by SBSTA 29	
Focus area	Actions	Deliverables	Actions	Deliverables	Actions	Deliverables	Actions	Deliverables
3.Climate modelling, scenarios and downscaling			Submission by 21 Sept'07 (IPCC, ROs of International, regional and national level) -Climate change scenarios, experience of using climate models, statistical outputs etc) -Miscellaneous document (secretariat)		In-session workshop (experts from Parties, IPCC and ROs)			Report from in-session workshop (secretariat)

Slide 15: OVERVIEW OF FINAL DELIVERABLES AND ACTIONS UNDERS THE FIVE YEAR PROGRAMME

Year	2007				2008		2009	
Session	Before/by SBSTA 26		Before/by SBSTA 27		Before/by SBSTA 28		Before/by SBSTA 29	
Focus area	Actions	Deliverables	Actions	Deliverables	Actions	Deliverables	Actions	Deliverables
4. Climate related risks and extreme events	Submission by 23 Feb 2007 (parties and Relevant orgs.) -Experience with assessment and management of current and future climate risks and impacts -gaps, needs, opportunities and constraints in predicting climate variability and impacts -Misc. Document (secretariat)		Workshop (parties and experts from relevant organizations)	Reports of the workshop (secretariat)				



Slide 16: OVERVIEW OF FINAL DELIVERABLES AND ACTIONS UNDERS THE FIVE YEAR PROGRAMME

Year	2007				2008		2009	
Session	Before/by SBSTA 26		Before/by SBSTA 27		Before/by SBSTA 28		Before/by SBSTA 29	
Focus area	Actions	Deliverables	Actions	Deliverables	Actions	Deliverables	Actions	Deliverables
5. Socio-economic information	Submission by 21 Sep 2007 (parties and relevant organizations -information and Views on socio-Economic aspects Of climate change, And how to improve The integration Of socio-economic Information into Impacts and vulnerability assessments -gaps, needs opportunities and constraints in understanding adaptive capacity			Miscellaneous Document (Secretariat)	Expert meeting at Secretariat -on ways and means to improve the integration of socio-economic information into impacts and vulnerability assessments	Report on the meeting (



Slide 17: OVERVIEW OF FINAL DELIVERABLES AND ACTIONS UNDER THE FIVE YEAR PROGRAMME

Year	2007				2008		2009	
Session	Before/by SBSTA 26		Before/by SBSTA 27		Before/by SBSTA 28		Before/by SBSTA 29	
Focus area	Actions	Deliverables	Actions	Deliverables	Actions	Deliverables	Actions	Deliverables
6. Adaptation planning and practices	Submission by 15 May 2007 (parties and relevant organizations -adaptation approaches, strategies, practices and technologies for adaptation at regional, national and local level.		Miscellaneous document (secretariat) Workshop to exchange information and views on existing adaptation practices, needs, gaps, opportunities etc (parties, relevant organizations, CS, business organization)	Report on workshop (secretariat)				

Slide 18: OVERVIEW OF FINAL DELIVERABLES AND ACTIONS UNDER THE FIVE YEAR PROGRAMME

Year	2007				2008		2009	
Session	Before/by SBSTA 26		Before/by SBSTA 27		Before/by SBSTA 28		Before/by SBSTA 29	
Focus area	Actions	Deliverables	Actions	Deliverables	Actions	Deliverables	Actions	Deliverables
7. Research				Synthesis report on -ongoing and planned adaptation research -adaptation research needs identified by parties and ROs (Secretariat)				



Slide 19: OVERVIEW OF FINAL DELIVERABLES AND ACTIONS UNDER THE FIVE YEAR PROGRAMME

Year	2007				2008		2009	
Session	Before/by SBSTA 26		Before/by SBSTA 27		Before/by SBSTA 28		Before/by SBSTA 29	
Focus area	Actions	Deliverables	Actions	Deliverables	Actions	Deliverables	Actions	Deliverables
8. Technologies for adaptation				Synthesis report on -technologies for adaptation identified by parties and ROs (secretariat)				

Slide 20: OVERVIEW OF FINAL DELIVERABLES AND ACTIONS UNDER THE FIVE YEAR PROGRAMME

Year	2007				2008		2009	
Session	Before/by SBSTA 26		Before/by SBSTA 27		Before/by SBSTA 28		Before/by SBSTA 29	
Focus area	Actions	Deliverables	Actions	Deliverables	Actions	Deliverables	Actions	Deliverables
9. Economic Diversification			Submissions by 17 August 2007 -Information on examples of measures, methodologies and tools to increase the economic resilience. (Parties and ROs)	Miscellaneous document (Secretariat) Synthesis Report on submissions				



Slide 21: EXPECTED OUTCOME OF THE FIVE-YEAR PROGRAMME OF WORK

The expected outcomes of the programme of work are:

- Enhanced capacity at international, regional, national, sectoral and local levels to further identify and understand impacts, vulnerability, and adaptation responses, and to select and implement practical, effective and high priority adaptation actions.
- Improved information and advice to the conference of the parties and its subsidiary bodies on the scientific, technical and socio-economic aspects of impacts, vulnerability and adaptation, including facilitating the implementation of decision 1/CP.10, where relevant.
- Enhanced development, dissemination and use of knowledge from practical adaptation activities.
- Enhanced cooperation among parties, relevant organizations, business, civil society, and decision makers, aimed at enhancing their ability to manage climate change risks.
- Enhanced integration of actions to adapt to climate change with sustainable development.

Slide 22: KEY CHALLENGES

- Resources limitation
- Coordination
- Monitoring and evaluation



ANNEX 5

PRESENTATION

ASSESSMENT OF MARINE BIODIVERSITY INDICATORS FOR THE GLOBAL ENVIRONMENT FACILITY RESOURCE ALLOCATION FRAMEWORK (GEF/RAF) IN THE SOUTH PACIFIC

presented by Bevis Fedder, Researcher FSPI

Slide 1: RESOURCE ALLOCATION FRAMEWORK

Issues and Approaches

Slide 2: OUTLINE

- Introduction
 - Issue
 - terrestrial vs. marine
 - Pacific SIDS
 - A solution
 - Your contribution
-

Slide 3: BASICS

- GEF: The financial mechanism of CBD Guidance of COP
 - RAF: - indicative country allocation
 - - compares countries internationally
 - uses indicators (GBI_{bio} and GPI)
 - global representation
 - rerun and reviewed at Mid-term review
-

Slide 4: CALCULATE THE ALLOCATION

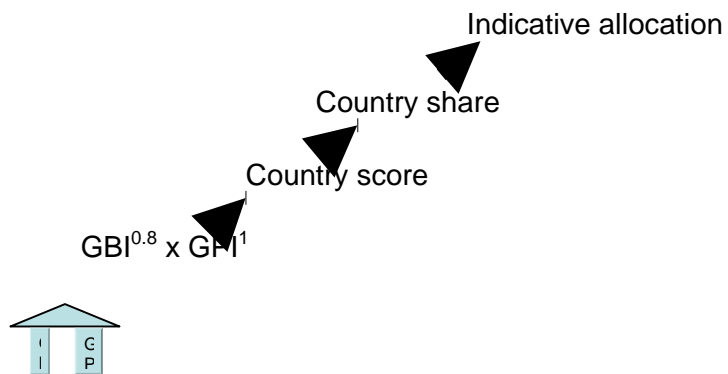

Slide 5: CALCULATION OF GBI_{bio}

$$GBI_{bio} = 0.8 \times \text{Terrestrial Score} + 0.2 \times \text{Marine Score}$$

Slide 6: ISSUE

Slide 7: ADVANTAGES/DISADVANTAGES

- √ Awareness
- √ Transparency
- √ GEF ready for improvement

- × marine discrimination
- × GPI extra burden
- × precautionary principle?
- × COP guidance?

Slide 8: MARINE SCORE AND GBI_{bio}

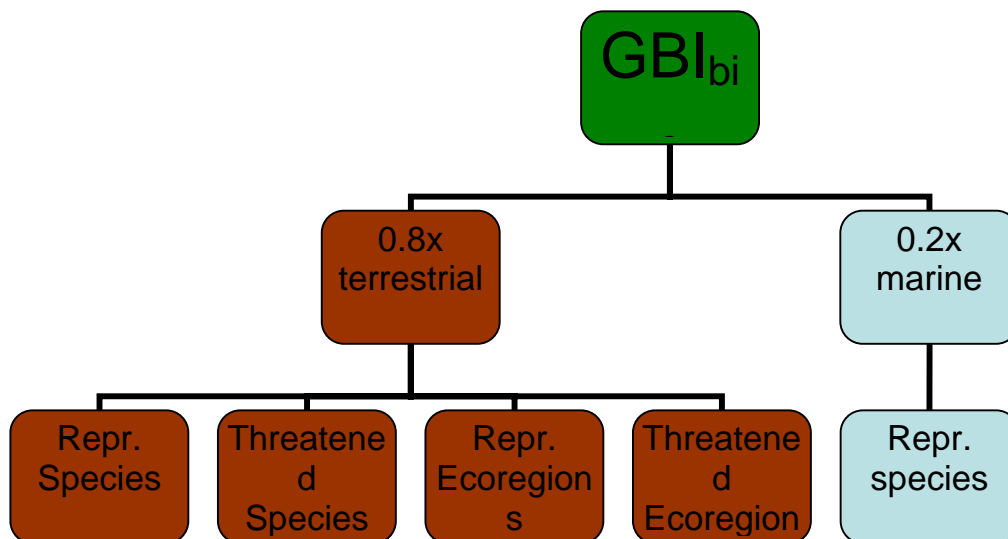

Slide 9: TERRESTRIAL vs. MARINE

Terrestrial natural environment
 distinct boundaries
 smaller areas
 normally 2-D
 distinct habitat
 → less expensive
 → easy sampling

Σ much data

Marine under the surface
 fuzzy, dynamic borders
 vast areas
 3-D
 interconnected habitats
 → more expensive
 → difficult sampling

few data

Slide 10: PACIFIC SIDS

Pacific SIDS marine biodiversity is not acknowledged:

- small terrestrial area – vast marine environment (EEZ)
 - extremely high marine biodiversity (e.g. Solomons)
 - good body of knowledge for some countries (e.g. Fiji, Solomons)
 - good environmental health
 - remoteness (Christmas islands)
 - sealoaked
-

Slide 11: A SOLUTION

Approaching the formula

Slide 12: POSSIBLE APPROACHES

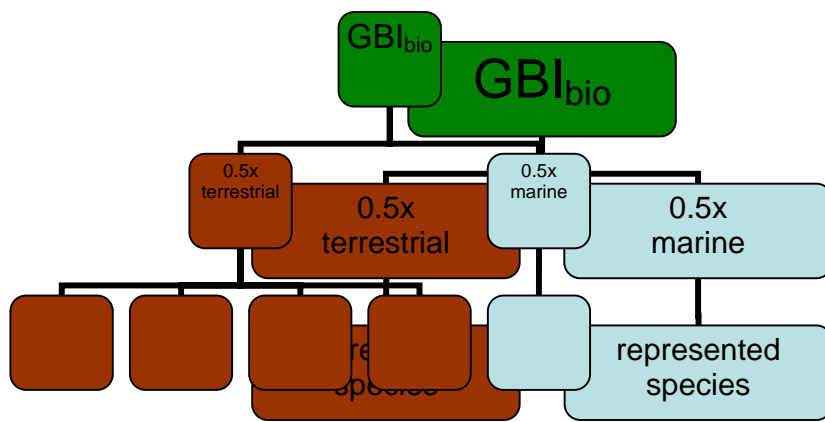

Slide 13: POSSIBLE APPROACHES

Possible approaches

[Intro](#)
[Issue](#)
[Idea](#)
[Help](#)

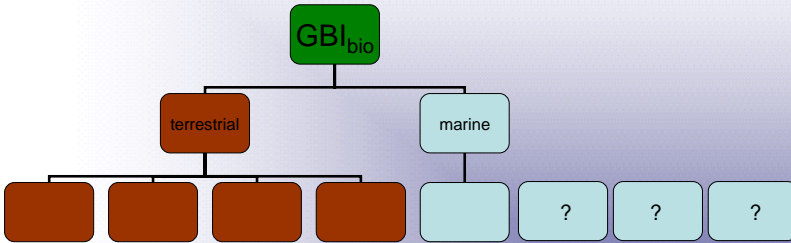

```

graph TD
    GBI_bio[GBIbio] --> T[terrestrial]
    GBI_bio --> M[marine]
    T --> T1[ ]
    T --> T2[ ]
    T --> T3[ ]
    T --> T4[ ]
    M --> M1[ ]
    M --> M2[?]
    M --> M3[?]
    M --> M4[?]
  
```





Slide 14: INDICATOR CRITERIA

- I) reflect marine biodiversity or threat to marine biodiversity
- II) global available
- III) based on existing data
- IV) complete by GEF-5
- V) indicators not more complex

Slide 15: TARGETS

- Explain current situation for Pacific SIDS
- Propose a new formula
- Predict scope of a new formula for Pac. SIDS
- Increase body of RAF relevant scientific knowledge
- Consider political implications on (inter-) national level
→ provide policy recommendation

Slide 16: POLITICAL IMPLICATIONS

- Countries focus on national biodiversity
→ But GEF puts emphasis on regional projects
- Collaborate with other recipient countries (e.g. SIDS)
→ endorsement at GEF
- Pac. SIDS needs to maximize utilization of RAF allocations
- Increase negotiation capacities

Slide 17: CONCERNS

- Might meet political resistance from other countries (e.g. land-locked states if 50/50)
- Incorporating marine indicators might compromise terrestrial indicators
→ reduce overall allocation
- Indicators might not challenge allocation significantly due to small size of SIDS (comp. large countries)



Slide 18: YOUR HELP REQUIRED!

Slide 19:

- Available time for data collection: End of March
→ no time for field work

 - What are possible globally complete indicators/data sets of marine biodiversity
-